

DIN EN 22 568

HOBBY NO/CS/WS
code 216 XXX

STANDARD HSS
code 246 XXX

STANDARD HSS
code 276 XXX

Závitové kruhové čelisti Circular dies Schneideisen Плашки

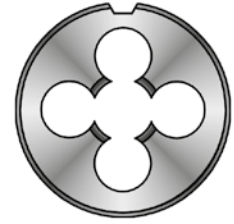
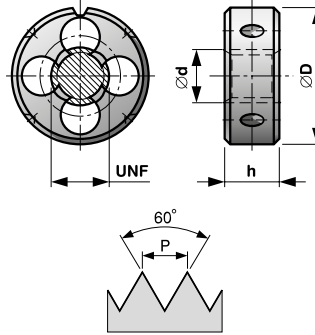

Licování: 2A / Tolerance: 2A /
Toleranz: 2A / Подгонка: 2A



1,5P

UNF

Unifikovaný jemný závit ASME B1.1
Unified fine thread ASME B1.1
Unifiziertes-Feingewinde ASME B1.1
Унифицированная мелкая резьба ASME B1.1

	z/1"	P	ØD	h	S		code ^{x)}
UNF 4	48	0,529	20	5	3	2,77	XXX 004
UNF 5	44	0,577	20	5	3	3,10	XXX 005
UNF 6	40	0,635	20	7	3	3,42	XXX 006
UNF 8	36	0,706	20	7	3	4,08	XXX 008
UNF 10	32	0,794	20	7	4	4,73	XXX 010
UNF 12	28	0,907	20	7	4	5,38	XXX 012
UNF 1/4	28	0,907	20	7	4	6,24	XXX 140
UNF 5/16	24	1,058	25	9	4	7,82	XXX 516
UNF 3/8	24	1,058	30	11	4	9,41	XXX 380
UNF 7/16	20	1,270	30	11	5	10,98	XXX 716
UNF 1/2	20	1,270	38	10	5	12,56	XXX 120
UNF 9/16	18	1,411	38	10	5	14,14	XXX 916
UNF 5/8	18	1,411	45	14	5	15,73	XXX 580
UNF 3/4	16	1,588	45	14	6	18,89	XXX 340
UNF 7/8	14	1,814	55	16	5	22,05	XXX 780
UNF 1	12	2,117	55	16	6	25,21	XXX 100
UNF 1 1/8	12	2,117	65	18	6	28,38	XXX 118
UNF 1 1/4	12	2,117	65	18	7	31,56	XXX 114
UNF 1 3/8	12	2,117	65	18	9	34,73	XXX 138
UNF 1 1/2	12	2,117	75	20	8	37,91	XXX 112

x) 216 XXX - NO / CS / WS

x) 246 XXX - HSS

x) 276 XXX - HSS s lamačem třísek / with spiral point / mit Schälanschnitt / с лопателем стружек



**BUČOVICE
TOOLS a.s.**

Materiál: NO; HSS - dle požadavku
Provedení: závit lapovaný do UNF 1"
Závit: pravý

Material: CS-carbon steel; HSS - on request
Execution: lapped thread to UNF 1"
Thread: right-hand

Werkstoff: WS-Werkzeugstahl; HSS - nach dem Anspruch
Ausführung: geläpftes Gewinde bis UNF 1"
Gewinde: rechts

Материал: NO-инструментальная сталь; HSS - по заказу
Изготовлено: резьба шлифованная до UNF 1"
Резьба: правая